

Gebrauchsanleitung PK-Nr. 3061
Instructions / Mode d'emploi / Gebruiksaanwijzing /
инструкция по использованию

TRANSLAND GmbH
Möbel und Textil
Hauptstraße 87
D-97840 Hafenlohr

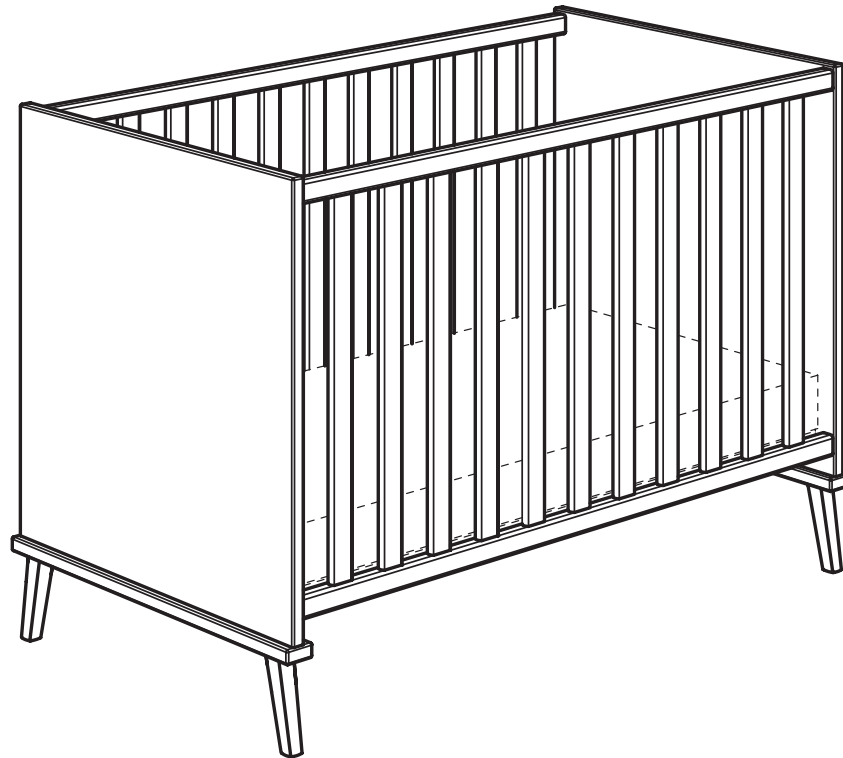

MALY
176 4470

Warnhinweis!

Warning notice! / Avertissement! / Waarschuwing! /
Предупреждение!

TRANSLAND GmbH
Möbel und Textil
Hauptstraße 87
D-97840 Hafenhof



V..

Vorbereitung / Preparation /
La préparation / Voorbereiding /
подготовка

M..

Montage / Assembly /
Assemblage / Bijeenkomst /
МОНТАЖ

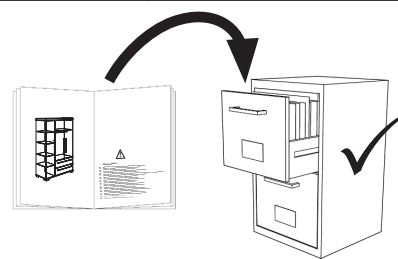

- DE** Schraubenverbindungen von Zeit zu Zeit auf ihre Festigkeit prüfen, gegebenenfalls nachziehen, da die Stabilität der Konstruktion sonst nicht gegeben ist.
- FR** Vérifier les connexions à vis de temps en temps, resserrer celles-ci le cas échéant, car, sinon, la stabilité de la construction ne serait pas assurée.
- GB** Check the tightness of the screw connections from time to time and tighten if necessary, as otherwise the stability of the construction is not assured.
- NL** Schroefverbindingen moeten van tijd tot tijd op hun stevigheid worden gecontroleerd en eventueel worden vastgedraaid, aangezien de stabiliteit van de constructie anders niet verzekerd is.
- ES** Compruebe de vez en cuando la firmeza de las uniones atornilladas y reapriete los tornillos si fuera necesario, pues de lo contrario quedaría afectada la estabilidad de la estructura.
- GR** Πού και πού ελέγχετε τη σταθερότητα των κοχλιωτών συνδέσεων κι εφ' όσον είναι ανάγκη, τις σφίγγετε ξανά, επειδή διαφορετικά δεν είναι η ευστάθεια της κατασκευής δεδομένη.
- IT** Controllare di tanto in tanto la tenuta delle connessioni a viti, all'occorrenza provvedere a serrarle di nuovo, poiché altrimenti non è garantita la stabilità della struttura.
- CZ** Čas od času zkontrolujte pevnost šroubových spojů, případně je dotáhněte, jinak nebude konstrukce stabilní.
- SL** Vijačne zveze od časa do časa preveriti glede na trdnost, po potrebi priviti, saj sicer stabilnost konstrukcije ne bo zagotovljena.
- PL** Połączenia śrubami sprawdzać od czasu do czasu pod kątem ich trwałości, ewentualnie dokręcać, gdyż inaczej konstrukcja nie jest stabilna.
- BG** Контролируйте от време на време дали болтовите съединения са добре завинтени, тъй като в противен случай не може да се гарантира стабилността на конструкцията.
- HR** Spojeve vijaka s vremena na vrijeme provjeriti u svezi čvrstoće, po potrebi stegnuti, jer inače nije zajamčena stabilnost konstrukcije.
- LT** Kartais patikrinkite varžtų jungčių stiprumą, prireikus suvėžkite juos stipriau, nes priešingu atveju konstrukcija nebus stabilii.
- RU** Перепроверяйте время от времени болтовые соединения. Они должны быть плотно затянуты. Это гарантирует стабильность конструкции.
- CN** 请经常的检查连接处的螺丝，如有发现松动请及时锁紧，否则将无法保障其稳定性。

- DE** **Pflegehinweis: Zum Reinigen der Oberflächen ein leicht-feuchtes Tuch oder ein handelsübliches Möbelpflegemittel verwenden.**
- FR** Indication sur l'entretien: pour nettoyer les surfaces, utiliser un chiffon légèrement humide ou un nettoyeur pour meubles en vente dans le commerce
- GB** Caring for the...: In order to clean the surfaces please use a slightly damp cloth or commercially available furniture care product.
- NL** Verzorgingsaanwijzing: Voor het reinigen van de oppervlakken een licht vochtig doek of een gebruikelijk meubelschoonmaakmiddel gebruiken.
- ES** Recomendaciones de cuidado: Para limpiar las superficies del mueble debe usar un trapo humedecido o un producto de limpieza de muebles comercial.
- GR** Οδηγίες περιποίησης: Για το καθάρισμα των επιφανειών να χρησιμοποιείτε ένα ελαφρά νοτισμένο πανάκι ή λούστρο επίπλων.
- IT** Indicazione per pulizia e cura: Per la pulizia delle superfici utilizzate un panno leggermente umido o un normale prodotto per la cura dei mobili.
- CZ** Pokyny k čištění: Na čištění povrchu použijte pouze navlhčený kousek látky nebo běžný prostředek na ošetřování nábytku.
- SL** Navodilo za nego: Za čiščenje površin uporabljajte malo vlažno cunjko ali trgovsko običajno sredstvo za nego pohištva.
- PL** Wskazówka pielęgnacyjna: do czyszczenia powierzchni stosować lekko wilgotną ściereczkę lub zwykły środek do pielęgnacji mebli.
- BG** Указание за поддръжане: Използвайте леко навлажнена кърпа или обикновен препарат за поддръжане на мебели, за да почистите повърхностите.
- HR** Upute za njegu: Za čišćenje površina upotrijebiti jednu lako navlaženu krpu i trgovačko uobičajeno sredstvo za njegu namještaja.
- LT** Rekomendacija priežiūrai: Paviršius valykite drėgna pašluoste arba parduotuvėse įsigytomis baldų priežiūros priemonėmis.
- RU** Рекомендации по уходу: для очистки поверхностей используйте слегка влажную тряпку или обычное средство по уходу за мебелью.
- CN** 保养说明: 清洁表面只需用稍微潮湿的布或普通的家具清洁剂即可。
- AR** إرشاد للعناية: يرجى من أجل تنظيف الأسطح استخدام منديل رطب بعض الشيء أو استخدام إحدى مواد تنظيف الأثاث المتوفرة في الأسواق التجارية.

Beschläge

Fittings / Raccords / Fittingen / кованы

TRANSLAND GmbH
Möbel und Textil
Hauptstraße 87
D-97840 Hafenlohr





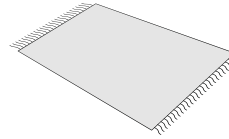
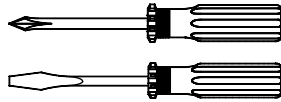
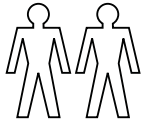
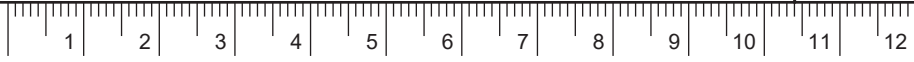



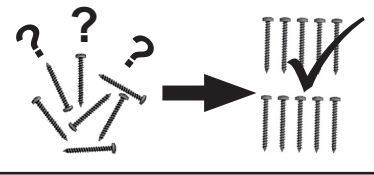

1:1
DIN A4

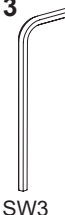
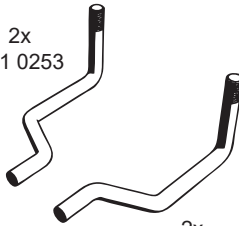

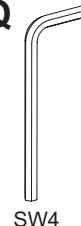
ca. 0,5h

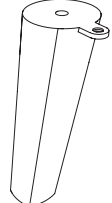

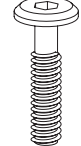
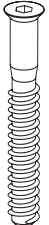

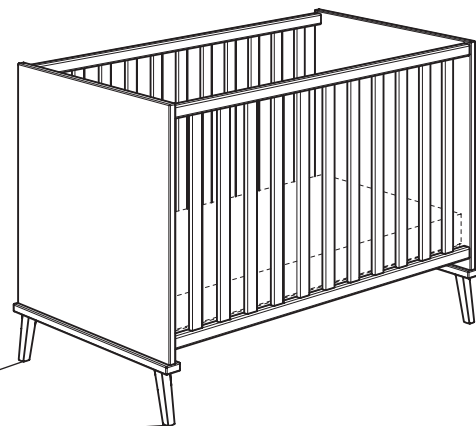
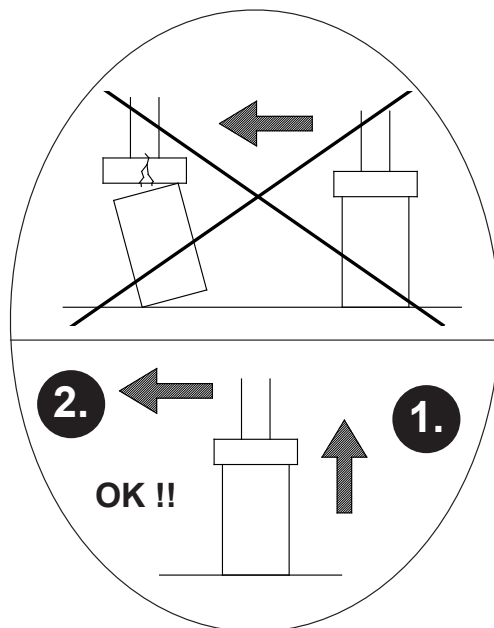

<p>B</p>  <p>8x 681 0775</p>	<p>C</p>  <p>18,5 mm 8x 681 0773</p>	<p>D2</p>  <p>8x 681 0784</p>	<p>D3</p>  <p>SW3 1x 681 3009</p>	<p>E</p>  <p>2x 681 0253 2x 681 0254</p>	<p>F</p>  <p>4x 681 2047</p>	<p>Q</p>  <p>SW4 1x 681 3011</p>
--	--	---	---	--	--	--

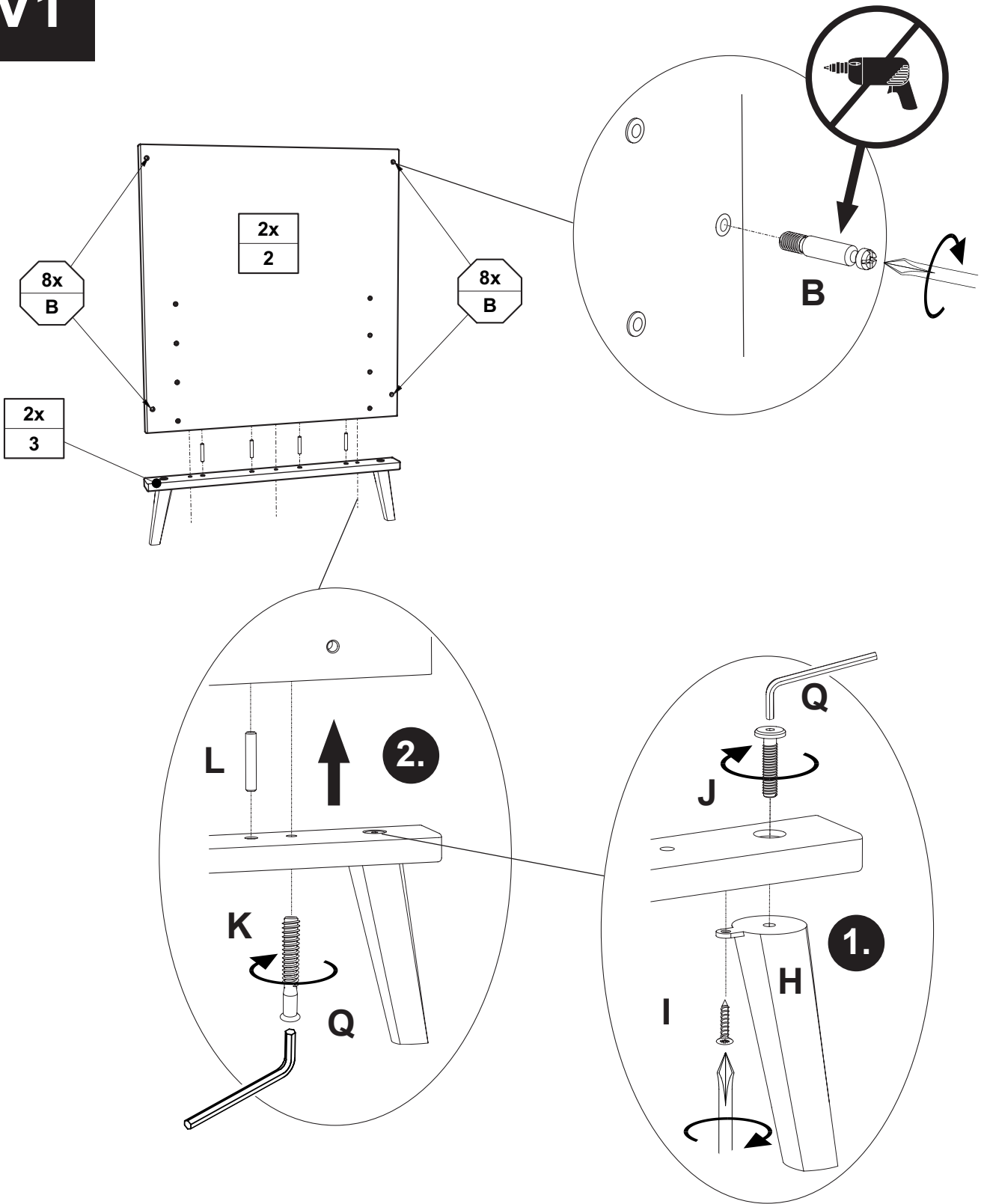
<p>H</p>  <p>4x 681 8550</p>	<p>I</p>  <p>3,5 x 15 4x 681 2639</p>	<p>J</p>  <p>M8 x 35 4x 681 3991</p>	<p>K</p>  <p>6,3 x 50 6x 681 5311</p>	<p>L</p>  <p>ø8 x 45 8x 681 0402</p>
---	---	--	--	---

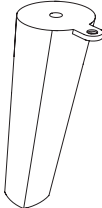

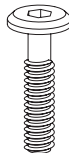

<p>Q</p>  <p>SW4 1x 681 3011</p>	<p>H</p>  <p>4x 681 8550</p>	<p>I</p>  <p>3,5 x 15 4x 681 2639</p>	<p>J</p>  <p>M8 x 35 4x 681 3991</p>	<p>K</p>  <p>6,3 x 50 6x 681 5311</p>	<p>L</p>  <p>ø8 x 45 8x 681 0402</p>
--	--	---	--	---	--

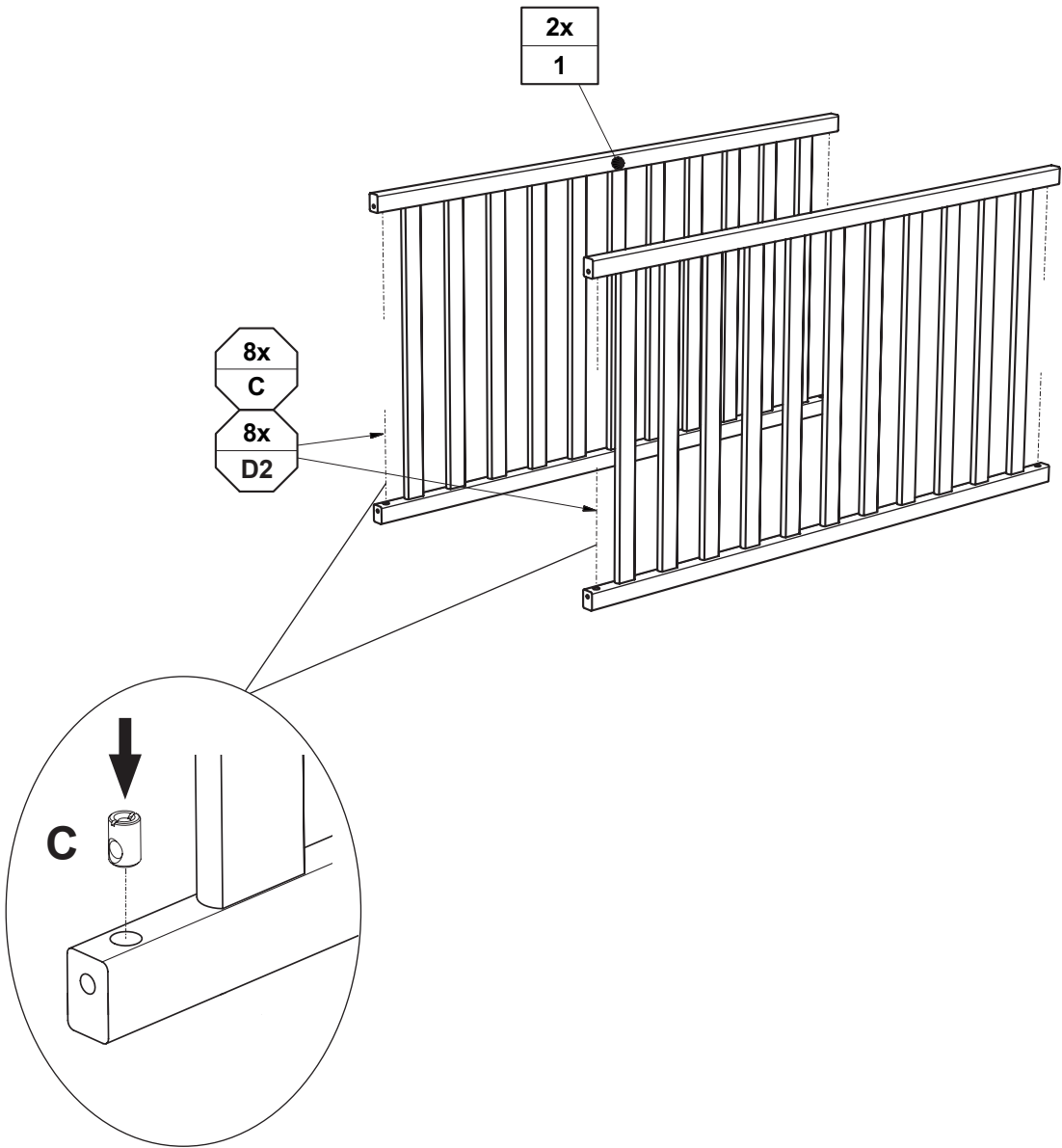

C

18,5 mm

8x
681 0773

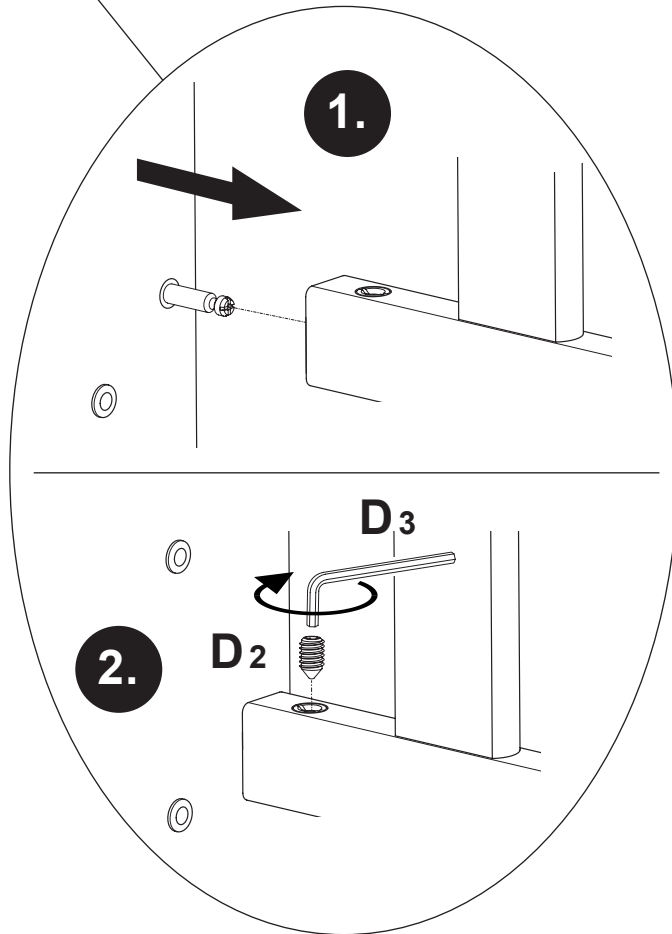
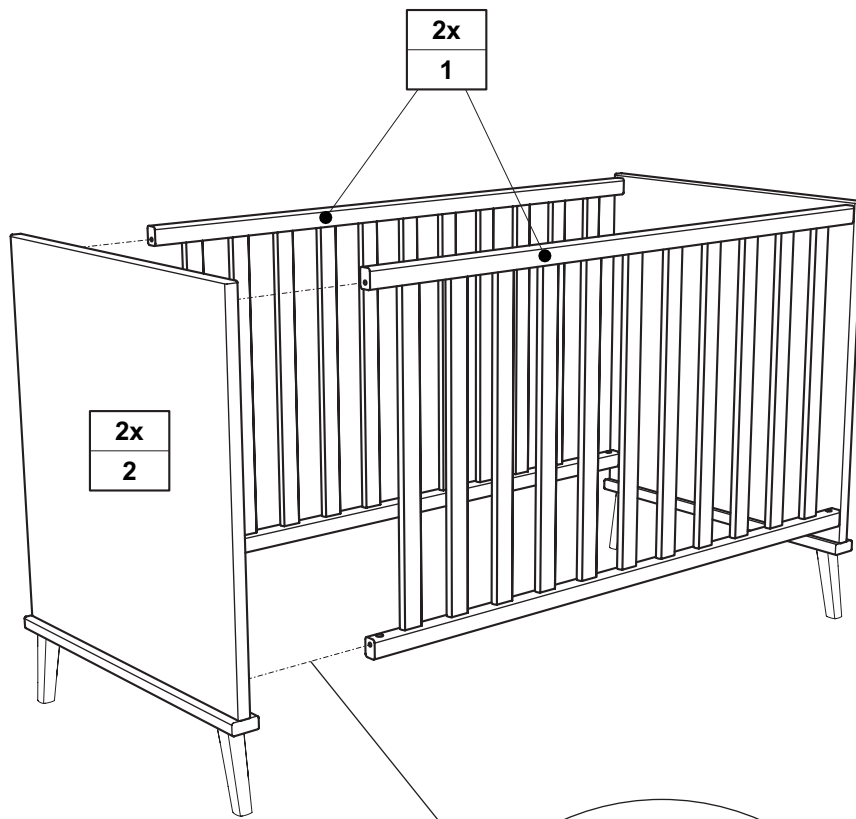

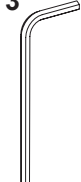
D2	D3
	
8x 681 0784	SW3 1x 681 3009

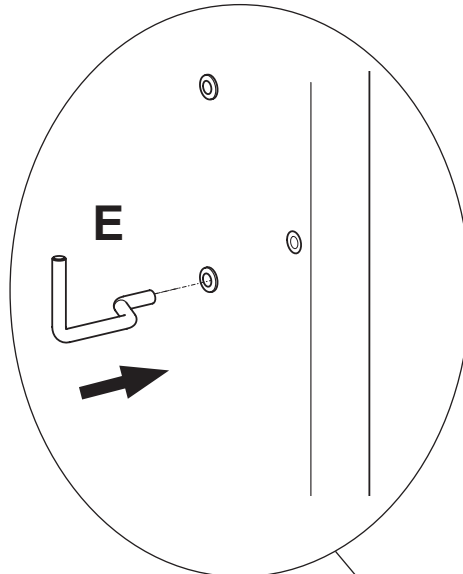
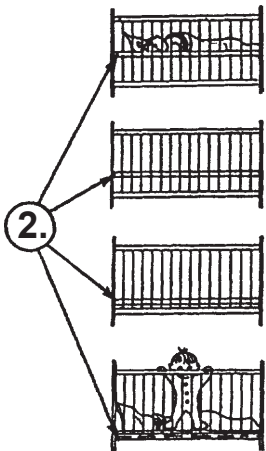

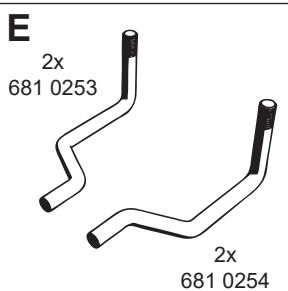
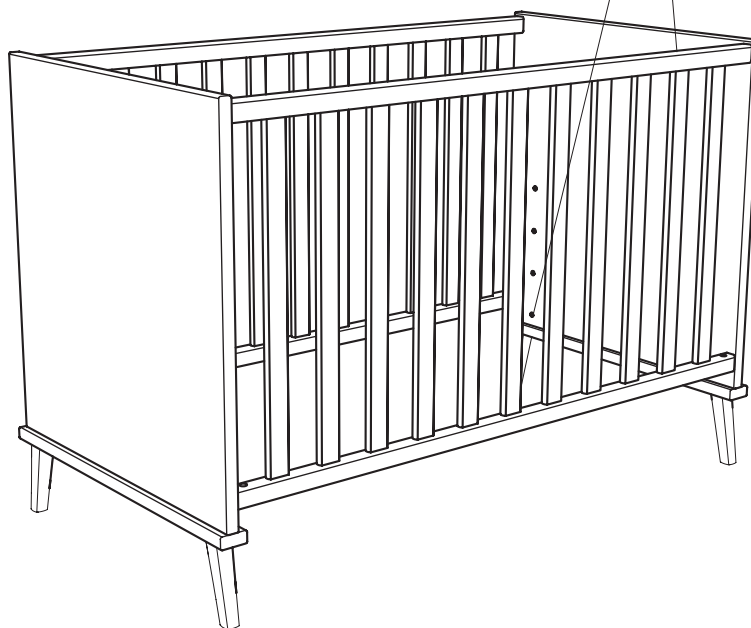
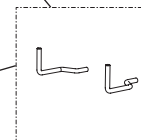

2x
E

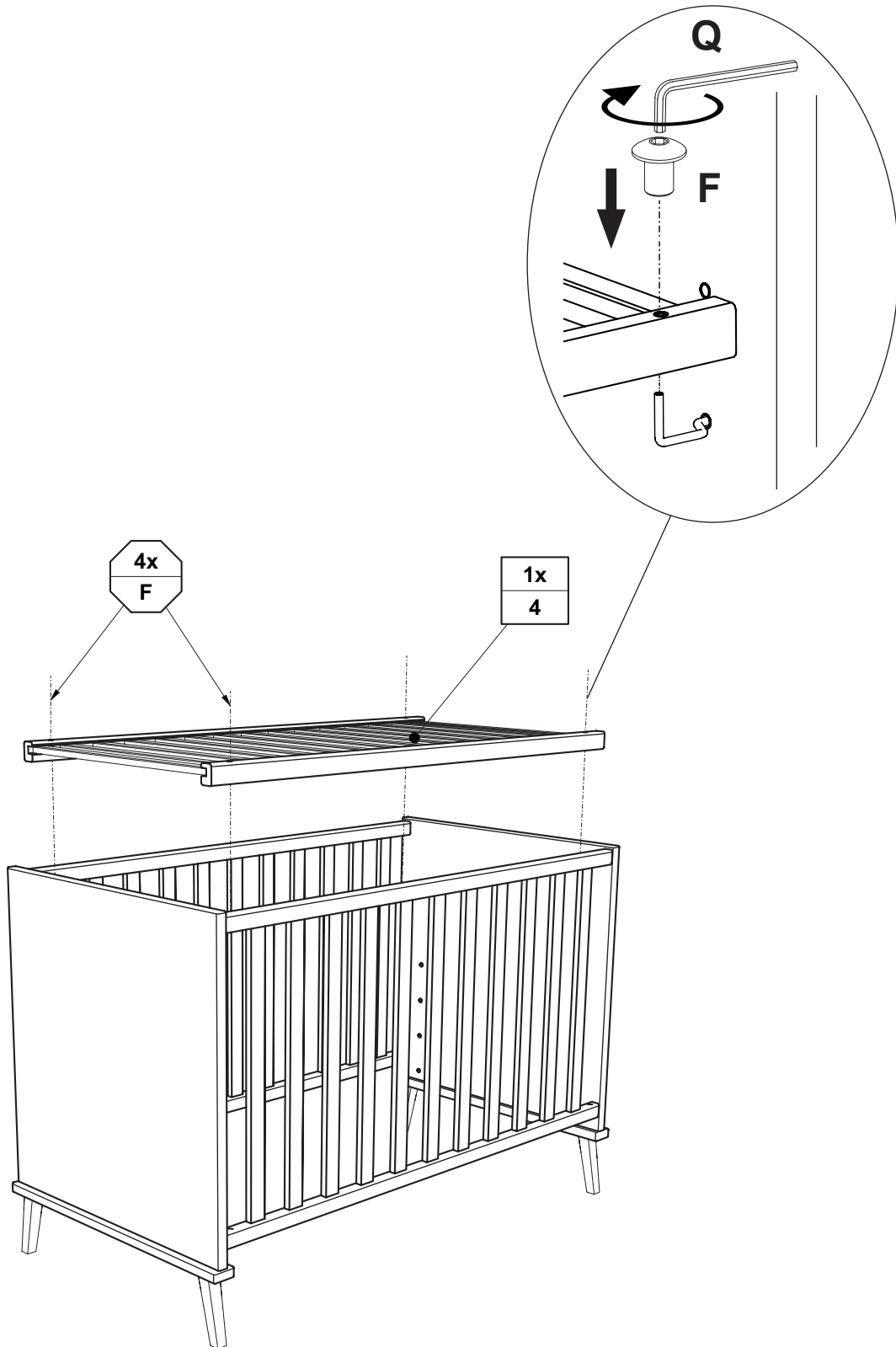



4x
F

1x
4

F	Q
	
4x 681 2047	SW4 1x 681 3011